

KEY EXPLANATION:

1. Port No. 1, Working
2. Port No. 2, Working
3. Poppet, Check, Hard Stainless
4. Poppet Check Spring, Stainless Steel
5. O-Ring Seals, Teflon
6. Filter, 10 Micron, Sintered Bronze
7. Vent (2 Pl.) Optional T Port Locations
8. Filter Retainer
9. Actuator Return Springs, Stainless Steel
10. Actuator Piston
11. Piston O-Ring Seal, Buna N (Also See Options)
12. Bonnet Stainless Steel
13. 1" Wrench Flats for Installation
14. Pilot Port X (Specify in Part Number)
15. Piston Sleeve, Stainless Steel
16. Push Rod, Hard Stainless Steel (17-4)
17. Cartridge Seat Retaining Ring
18. Mount O-Ring, -910, Buna-N (Also see Options)
19. 7/8-14 Cartridge Mounting Threads, Stainless Steel
20. Cartridge Seat, Hard Stainless
21. Back Up Ring, -014, Teflon
22. O-Ring Seal, -014, Buna N (Also See Options)

FUNCTION

Pilot Operated Check Valve.
 Normally closed. Pilot to Open.
 In the non-energized (non-piloted) condition:
 Flow is checked from 1 to 2.
 Flow will occur from 2 to 1 with 6 PSI Crack.
 In the energized (Piloted) condition:
 Flow will occur in either direction.
 Pilot area (X) is isolated from working ports 1 & 2.

7:1 PILOT RATIO:

The Pilot Ratio is a comparison between the seat seal area (key 3) poppet and the Actuator Pilot Piston (key 10). To determine pilot pressure required, divide the maximum working pressure by the pilot ratio of 7 and add 100 PSI for springs (key 9). The result represents the absolute minimum pilot pressure required to actuate the valve. Add a comfortable margin of pressure to assure reliable operation. Stay within the pressure limit of the pilot area (5,000 PSI).

PERFORMANCE (cartridge only)

Pressure Drop (PSI)
 Compared to Flow (GPM)

Valve Orifice Diameter = .250"
 Check Bias Spring Crack = 6 PSI

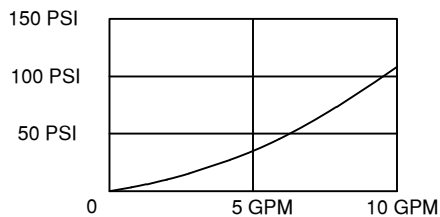

CARTRIDGE VALVE

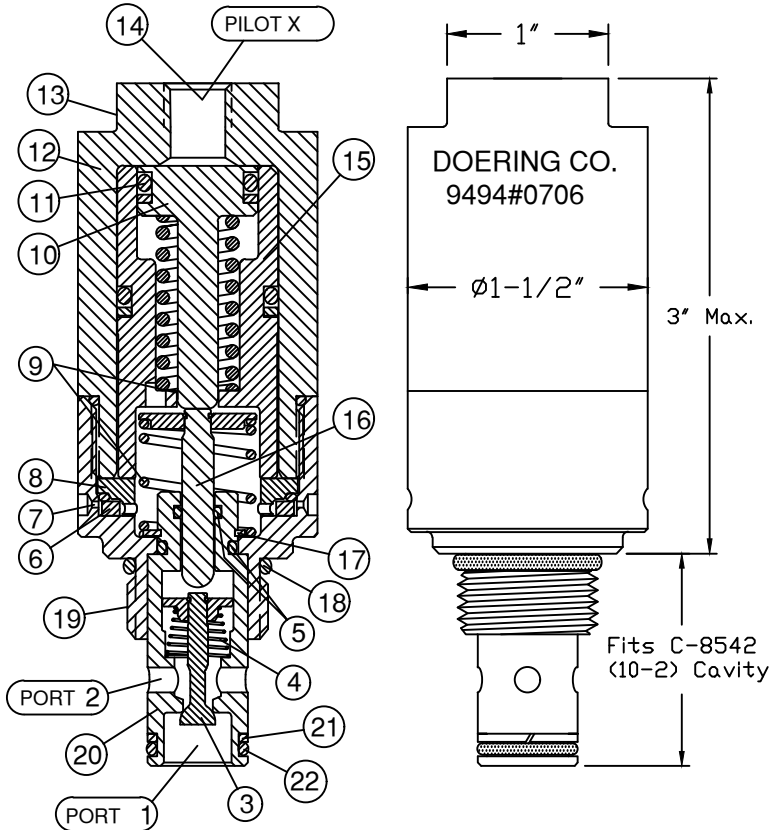

Order P/N 9494#0706

SPECIFY PILOT PORT X

- 1 = 1/8 NPT
- 2 = 1/4 NPT
- 4 = SAE4
- 6 = SAE6

Cavity & Housing

Cavity Drawing C-8542 (10-2):
 1200621 Spec. Sheet

Line Mount Housings:
 1200674 and 1201455
 Spec. Sheets

Panel Mount Housings:
 1202982 and 1202990
 Spec. Sheets

SPECIFICATIONS

Hydraulic or Gas Pilot Operated Check Valve.
 Pilot (X) Hydraulic or Gas mediums.
 Pilot Pressure Range, 100 PSI Min. to 5000 PSI Max.
 See 14:1 Pilot Ratio: notes for more information.
 Working Ports (1 and 2) Rated to 5,000 PSI.

Fluid temperatures -40°F (-40°C) to 200°F (93.3°C)
 Install Cartridge valve using 1" wrench
 Valve should screw in freely to the Mount Seal.
 Final tightening 20 to 30 foot pounds torque.
 Use lubricant on external oil seals and mounting threads.

OPTIONS

All Stainless Steel option, add -SS to Part Number.
 Standard seals are Buna-N with Teflon back up rings.
 Optional seals include EP, Viton, Teflon and others.
 Key 7, Vents to atmosphere (2 Places 180° apart).
 T Option provides 10-32 Threaded ports at these locations. With T option, Key 6, Sintered Bronze filter, is omitted from the assembly.

FUNCTIONAL SYMBOL

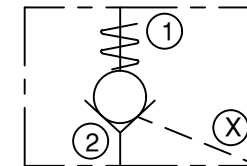

POC SERIES

Pilot Operated Check Valve
 Normally Closed. Pilot to Open.

6343 RIVER ROAD SE ■ CLEAR LAKE, MN 55319 USA
 Telephone: 320-743-2276 ■ Fax: 320-743-3723
 mailbox@doering.com ■ www.doering.com



DOERING